

This document was generated on 06/01/2010

PLEASE CHECK WWW.MOLEX.COM FOR LATEST PART INFORMATION

Part Number: **0039000095**
Status: **Active**
Overview: [minifit_jr](#)
Description: 4.20mm (.165") Pitch Mini-Fit™ Crimp Terminal, Male, Brass, Gold (Au), 16 AWG, Reel

Documents:

Test Summary (PDF)	Product Specification PS-5556-003 (PDF)
Drawing (PDF)	Product Specification PS-58691-004 (PDF)
Product Specification PS-5556-001 (PDF)	RoHS Certificate of Compliance (PDF)
Product Specification PS-5556-002 (PDF)	

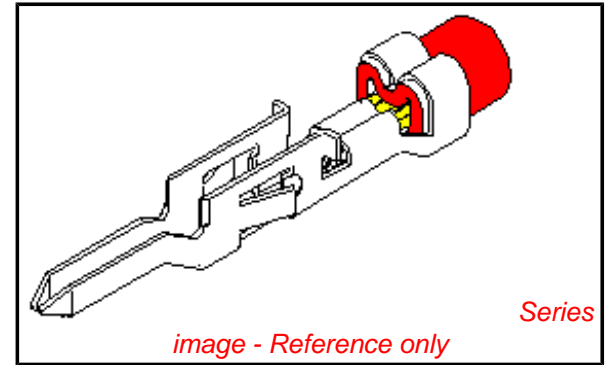

General

Product Family	Crimp Terminals
Series	5558
Crimp Quality Equipment	Yes
Overview	minifit_jr
Product Name	Mini-Fit®

Physical

Durability (mating cycles max)	30
Gender	Male
Material - Metal	Brass
Material - Plating Mating	Gold
Material - Plating Termination	Tin
Packaging Type	Reel
Plating min: Mating (µin)	30.4
Plating min: Mating (µm)	0.76
Plating min: Termination (µin)	81.2
Plating min: Termination (µm)	2.03
Termination Interface: Style	Crimp or Compression
Wire Insulation Diameter	1.80-3.10mm (.071-.122")
Wire Size AWG	16
Wire Size mm²	N/A

Electrical

Current - Maximum per Contact	9A
Voltage - Maximum	600V

Material Info

Old Part Number	5558GS3
-----------------	---------

Reference - Drawing Numbers

Application Specification	AS-58696-004
Packaging Specification	PK-5558-001
Product Specification	PS-5556-001, PS-5556-002, PS-5556-003, PS-58691-004, RPS-51200-003, RPS-58691-003, RPS-58719-004
Sales Drawing	SD-5558-002
Test Summary	TS-5556-002

EU RoHS

**ELV and RoHS
Compliant**
REACH SVHC
 Not Reviewed
**Halogen-Free
Status**
 Not Reviewed

China RoHS



**Need more information on product
environmental compliance?**

Email productcompliance@molex.com
 For a multiple part number RoHS Certificate of
 Compliance, [click here](#)

Please visit the [Contact Us](#) section for any
 non-product compliance questions.

Search Parts in this Series

5558Series

Mates With

5556 Mini-Fit™ Crimp Terminal

Use With

5559 Mini-Fit Jr.™ Plug Housing

Application Tooling | FAQ

*Tooling specifications and manuals are
 found by selecting the products below.
 Crimp Height Specifications are then
 contained in the Application Tooling
 Specification document.*

Global

Description	Product #
FineAdjust™	0639015300
Applicator for Mini-Fit Jr.™, Mini-Fit HCS™ Crimp Terminals, 16 AWG and smaller insulation	
T2 Terminator	0639102800
Tooling Die	

www.Datasheet.com

FineAdjust™ Applicator	<u>0639003000</u>
FineAdjust™ Applicator	<u>0639003000</u>
T2 Terminator Tooling Die	<u>0639103000</u>
Extraction Tool	<u>0011030044</u>
Hand Crimp Tool for Mini-Fit™ Jr. Male and Female Crimp Terminals, 16-24 AWG	<u>0638190900</u>
Japan	
Description	Product #
Applicator for M21 1A Bench Press, 18-24 AWG, for 5556 and 5558 Crimp Terminal Side-Feed Applicator For Full-Auto Machine	<u>0570223000</u> <u>0570223200</u>

This document was generated on 06/01/2010

PLEASE CHECK WWW.MOLEX.COM FOR LATEST PART INFORMATION

10 9 8 7 6 5 4 3 2 1

NOTES

1. MATERIAL: SEE CHART
2. FINISH: SEE CHART
3. PRODUCT SPECIFICATION: PS-5556-001, PS-5556-002, PS-5556-003.
4. PACKAGING SPECIFICATION: PK-5558-001 FOR CHAIN
PK-5556-003 FOR LOOSE
5. MATES WITH TERMINAL: 5556 SERIES.
6. APPLICABLE HOUSING: 5559, 30068, 42475 SERIES.
7. THE NUMBER OF SERRATIONS TO BE ONE FOR WIRE RANGE #22-28.
8. WHEN TERMINALS ARE INSTALLED IN THE HOUSING THE WIRES ARE TO BE DRESSED IN SUCH A MANNER TO ALLOW THE TERMINALS TO FLOAT FREELY IN THE POCKET.
9. THIS TERMINAL IS DESIGNED FOR SINGLE WIRE CRIMPING.
10. PART CONFORMS TO CLASS "B" REQUIREMENTS OF COSMETIC SPECIFICATION PS-45499-002.

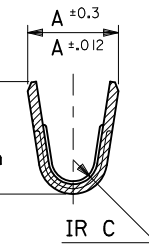
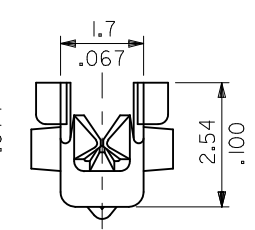
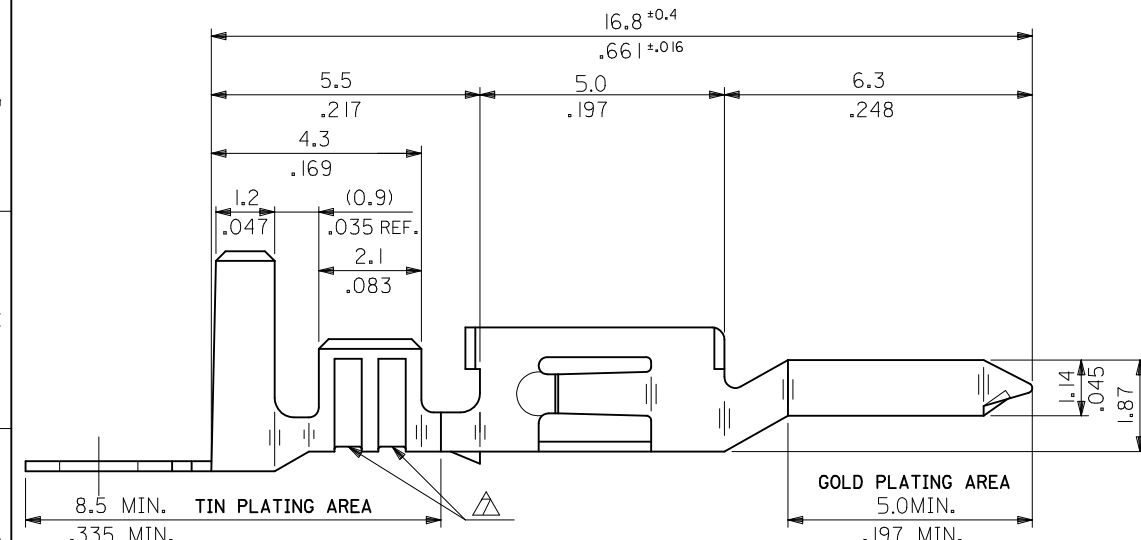
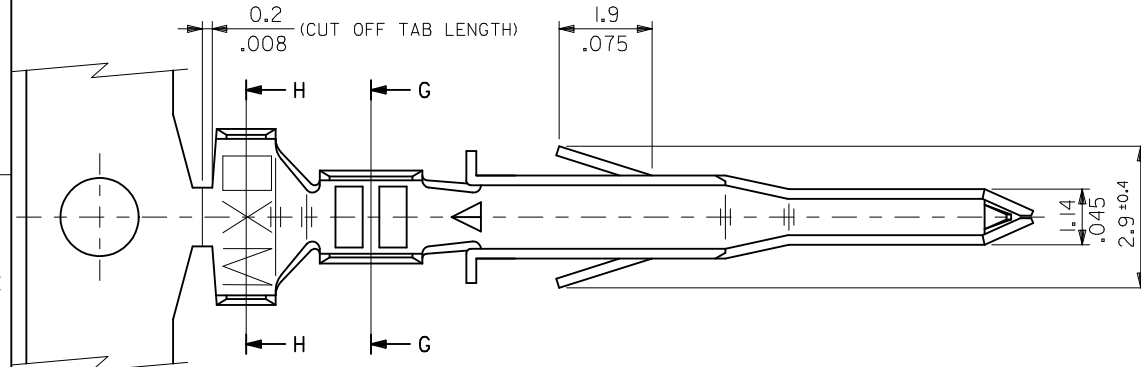

SECT. G-G

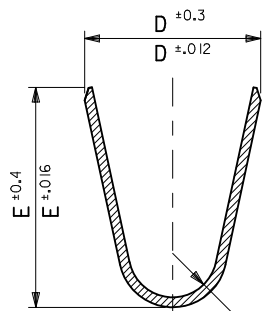

SECT. H-H

www.DataSheet4U.com

UPDATE NOTES EC NO: UCP2010-2478 DRWN: J JAGUILAR 2010/04/06 CHKD: JBELL '92/05/21 APPR: FSMITH 2010/04/09	QUALITY SYMBOLS F7=0 F7=0 F7=0	GENERAL TOLERANCES (UNLESS SPECIFIED) 4 PLACES ± -- ± -- 3 PLACES ± -- ± .008 2 PLACES ± 0.20 ± .008 1 PLACE ± 0.2 ± --- ANGULAR ± 3 °	DIMENSION STYLE MM/IN DRAWN BY H.HIRAMOTO DATE '91/03/13 CHECKED BY M.FUKUSHIMA DATE '92/05/21 APPROVED BY FSMITH DATE 2010/04/09	SCALE 10:1	DESIGN UNITS METRIC	THIRD ANGLE PROJECTION
	TITLE MINI-FIT JR SELECT GOLD MALE CRIMP TERMINAL -LEAD FREE-					
	MATERIAL NO. SEE CHART					
	DOCUMENT NO. SD-5558-002					
DRAFT WHERE APPLICABLE MUST REMAIN WITHIN DIMENSIONS			SIZE B		SHEET NO. 1 OF 2	

1b_frame_B_P_ME_T Rev. F 2009/06/18

9 8 7 6 5 4 3 2 1

PHOSPHOR BRONZE	SELECTIVE GOLD 0.76µm /30m.i. MIN. AND SELECTIVE TIN 2.03µm /80m.i. MIN. OVER NICKEL 1.27µm /50m.i. MIN.	0.9 .035	4.5 .177	3.6 .142	0.6 .024	2.7 .106	2.3 .091	∅ 3.1 .122 MAX.	# 16	39-00-0224	5558 PBGS3L	LOOSE
		0.6 .024	2.3 .091	2.3 .091	0.4 .016	1.65 .065	1.8 .071	∅ 0.9-1.8 .035-.071	#22-28	↑ -0223	↑ PBGS3	CHAIN
		0.6 .024	2.3 .091	2.3 .091	0.4 .016	1.65 .065	1.8 .071	∅ 0.9-1.8 .035-.071	#22-28	-0222	PBGS2L	LOOSE
		0.9 .035	4.5 .177	3.6 .142	0.5 .020	2.3 .091	1.9 .075	∅ 1.3-3.1 .051-.122	# 18-24	-0221	PBGS2	CHAIN
		0.9 .035	4.5 .177	3.6 .142	0.5 .020	2.3 .091	1.9 .075	∅ 1.3-3.1 .051-.122	# 18-24	-0220	PBGS1	LOOSE
		0.9 .035	4.5 .177	3.6 .142	0.5 .020	2.3 .091	1.9 .075	∅ 1.3-3.1 .051-.122	# 18-24	-0219	PBGS	CHAIN
		0.9 .035	4.5 .177	3.6 .142	0.6 .024	2.7 .106	2.3 .091	∅ 3.1 .122 MAX.	# 16	-0148	GS9L	LOOSE
		0.6 .024	2.3 .091	2.3 .091	0.4 .016	1.65 .065	1.8 .071	∅ 0.9-1.8 .035-.071	#22-28	↓ -0147	GS9	CHAIN
		0.6 .024	2.3 .091	2.3 .091	0.4 .016	1.65 .065	1.8 .071	∅ 0.9-1.8 .035-.071	#22-28	↓ -0146	GS8L	LOOSE
		0.9 .035	4.5 .177	3.6 .142	0.5 .020	2.3 .091	1.9 .075	∅ 1.3-3.1 .051-.122	# 18-24	39-00-0145	GS8	CHAIN
		0.9 .035	4.5 .177	3.6 .142	0.5 .020	2.3 .091	1.9 .075	∅ 1.3-3.1 .051-.122	# 18-24	40-13-0854	GS7L	LOOSE
		0.9 .035	4.5 .177	3.6 .142	0.5 .020	2.3 .091	1.9 .075	∅ 1.3-3.1 .051-.122	# 18-24	40-13-0853	GS7	CHAIN
BRASS	SELECTIVE GOLD 1.27µm /50m.i. MIN. AND SELECTIVE TIN 2.54µm /100m.i. MIN. OVER NICKEL 1.27µm /50m.i. MIN.	0.9 .035	4.5 .177	3.6 .142	0.6 .024	2.7 .106	2.3 .091	∅ 3.1 .122 MAX.	# 16	39-00-0100	GS6L	LOOSE
		0.6 .024	2.3 .091	2.3 .091	0.4 .016	1.65 .065	1.8 .071	∅ 0.9-1.8 .035-.071	#22-28	↑ -0099	GS6	CHAIN
		0.6 .024	2.3 .091	2.3 .091	0.4 .016	1.65 .065	1.8 .071	∅ 0.9-1.8 .035-.071	#22-28	-0098	GS5L	LOOSE
		0.6 .024	2.3 .091	2.3 .091	0.4 .016	1.65 .065	1.8 .071	∅ 0.9-1.8 .035-.071	#22-28	-0097	GS5	CHAIN
		0.9 .035	4.5 .177	3.6 .142	0.5 .020	2.3 .091	1.9 .075	∅ 1.3-3.1 .051-.122	# 18-24	-0076	GS4L	LOOSE
		0.9 .035	4.5 .177	3.6 .142	0.5 .020	2.3 .091	1.9 .075	∅ 1.3-3.1 .051-.122	# 18-24	-0075	GS4	CHAIN
	SELECTIVE GOLD 0.76µm /30m.i. MIN. AND SELECTIVE TIN 2.03µm /80m.i. MIN. OVER NICKEL 1.27µm /50m.i. MIN.	0.9 .035	4.5 .177	3.6 .142	0.6 .024	2.7 .106	2.3 .091	∅ 3.1 .122 MAX.	# 16	-0096	GS3L	LOOSE
		0.6 .024	2.3 .091	2.3 .091	0.4 .016	1.65 .065	1.8 .071	∅ 0.9-1.8 .035-.071	#22-28	-0095	GS3	CHAIN
		0.6 .024	2.3 .091	2.3 .091	0.4 .016	1.65 .065	1.8 .071	∅ 0.9-1.8 .035-.071	#22-28	-0433	GS2L7F	LOOSE
		0.6 .024	2.3 .091	2.3 .091	0.4 .016	1.65 .065	1.8 .071	∅ 0.9-1.8 .035-.071	#22-28	-0432	GS27F	CHAIN
		0.9 .035	4.5 .177	3.6 .142	0.5 .020	2.3 .091	1.9 .075	∅ 1.3-3.1 .051-.122	# 18-24	↓ -0431	↓ GSL7F	LOOSE
		0.9 .035	4.5 .177	3.6 .142	0.5 .020	2.3 .091	1.9 .075	∅ 1.3-3.1 .051-.122	# 18-24	39-00-0430	5558 GS7F	CHAIN
MATERIAL	FINISH	F	E	D	C	B	A	INS. RANGE	WIRE RANGE	EDP NO.	ENG NO.	FORM

www.DataSheet4U.com

UPDATE TITLE BLOCK EC NO: UCP2010-2478 DRWN: J JAGUILAR 2010/04/06 CHKD: JBELL '92/05/21 APPR: FSMITH 2010/04/09 REV E1	QUALITY SYMBOLS ∇=0 ∇=0 ∇=0	GENERAL TOLERANCES (UNLESS SPECIFIED)		DIMENSION STYLE MM/IN		SCALE 10:1	DESIGN UNITS METRIC	THIRD ANGLE PROJECTION		
		4 PLACES ± -- ± --- 3 PLACES ± -- ± .008 2 PLACES ± 0.20 ± .008 1 PLACE ± 0.2 ± ---	mm INCH ± --- ± --- ± .008 ± .008 ± .008 ± ---	DRAWN BY H.HIRAMOTO	DATE '91/03/13	TITLE MINI-FIT JR SELECT GOLD MALE CRIMP TERMINAL -LEAD FREE-		MOLEX INCORPORATED		SHEET NO. 2 OF 2
		ANGULAR ± 3 °		CHECKED BY M.FUKUSHIMA	DATE '92/05/21	MATERIAL NO. SEE CHART		DOCUMENT NO. SD-5558-002		THIS DRAWING CONTAINS INFORMATION THAT IS PROPRIETARY TO MOLEX INCORPORATED AND SHOULD NOT BE USED WITHOUT WRITTEN PERMISSION
		DRAFT WHERE APPLICABLE MUST REMAIN WITHIN DIMENSIONS		APPROVED BY FSMITH		DATE 2010/04/09		MOLEX INCORPORATED		THIS DRAWING CONTAINS INFORMATION THAT IS PROPRIETARY TO MOLEX INCORPORATED AND SHOULD NOT BE USED WITHOUT WRITTEN PERMISSION